

# CONSTANT CURRENT CHARGER LINE

## Industrial Truck Battery Charger



The constant current chargers are designed to have a nearly flat charge curve. The output will taper only slightly in order to maintain the AC amp draw as the battery voltage rises. It is an ideal choice for situations where several batteries of different cell and amp hour sizes are being charged. There are multiple uses such as rental fleets, service loaners, and battery-service shop use. Depending on your application we have two different styles to choose from. The CCS models are designed for higher output current requirements. These models are available in both single and three phase. Because of the AC input current draws needed, these chargers are typically used in a fixed location and hard wired to the building AC service. The CCS line is available with automatic or mechanical time. Refer to the Model Matrix for available sizes.



For the loaner type applications there is the LS2/24-28C model that is available with automatic control only. This model comes with a heavy-duty wheeled cart that gives you rugged portability, cable storage, and tie down capability. It is designed to charge from 2 and 24 cells at 28 amps output.. It can be plugged into any 120 volt receptacle. The charger comes complete with 8 ft. of 14/3 AC power cord with a 15 amp molded plug and 10' of DC power cable.



# Constant Current Shop Charger Models

Max. Cells	Amp hr. Rating	DC Amps	SINGLE PHASE					Case
			Model	AC Input Amps				
				120	208	240	480	
24	510	40	CCS24-510A1	22.40	12.90	11.20		500
36	680	50	CCS36-680B1		24.00	21.00	10.50	501
36	1000	75	CCS36-1000B1		36.00	31.50	15.80	501
36	1350	100	CCS36-1350B1		48.50	42.00	21.00	501

Max. Cells	Amp hr. Rating	DC Amps	THREE PHASE					Case
			Model	AC Input Amps				
				120	208	240	480	
36	950	75	CCS36-950B3		21.00	18.20	9.10	501
36	1400	100	CCS36-1400B3		28.00	24.20	12.10	501
36	2000	150	CCS36-2000B3		42.00	36.30	18.10	502

\* Requires 60Hz Voltage Code

C= 120/208/240

B= 208/240/480

F.O.B. First Destination, Continental USA

Prices and Specifications subject to change

**Battery Connector Plug Guard**  
 Option 38-151(Single) or 38-199(Dual plug)  
 A metal shroud that protects the battery cable connector from damage.

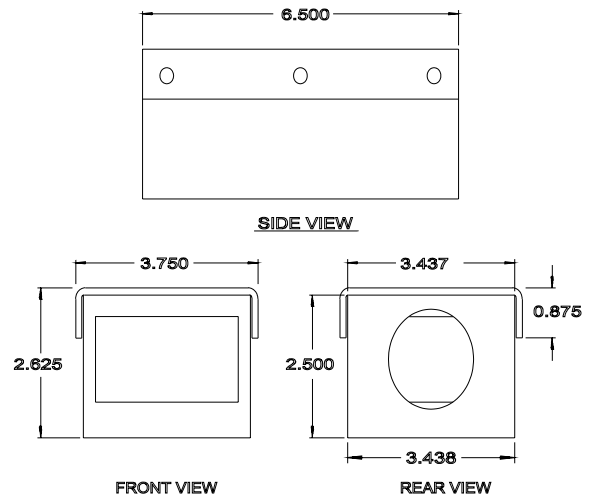

**Your Constant Current Distributor:**